

UDC 615. 471.03:616.073

S.V. Pavlov¹, Waldemar Wójcik², R.L. Holyaka³,
O.D. Azarov¹, L.E. Nykyforova⁴, O.V.Kaduk¹

ELECTRIC THERMAL MODELING OF TEMPERATURE-DEPENDENT VAC OF THE TRANSISTOR-TYPE CONVERTERS IN BIOMEDICAL ENGINEERING

¹Vinnitsia National Technical University, 95, Khmelnitske shosse, 21021, Vinnitsia, Ukraine,²Lublin University of Technology, Poland³Lviv Polytechnic National University, Ukraine⁴National University of Life and Environmental Sciences of Ukraine

Анотація. В статті розглянуто шляхи вирішення проблеми нестабільності ітераційних процесів при аналізі ВАХ вимірювальних перетворювачів з від'ємним диференціальним опором, обумовленим самонагрівом цих перетворювачів. Розроблено експрес-метод визначення меж, в яких забезпечується коректний електротепловий DC аналіз. Відповідно до розглянутої задачі розроблено методу синтезу електротермічної моделі транзисторних структур термодатчиків потоку. Аналізуючи модель біполярного транзистора з точки зору впливу температури саморозігріву на ВАХ, необхідно розглянути, як мінімум, три механізми впливу температури. Слід зазначити, що, як і в представлених раніше моделях, мова йде не тільки про вплив температури навколишнього середовища на параметри транзистора, але і про його самонагрівання, тобто про прямий вплив потужності, що виділяється в структурі транзистора, на його електрофізичні параметри. Запропоновано спосіб синтезу електротеплових моделей терморезистивних, діодних та транзисторних структур первинних перетворювачів теплових сенсорів потоку. На відміну від відомих пакетів схемного моделювання (PSpice чи MicroCAP) запропонований спосіб дозволяє за один цикл DC аналізу отримати ВАХ з врахуванням самонагріву вищевказаних перетворювачів. Розроблено комплексну методику електротеплового моделювання вимірювальних перетворювачів теплових сенсорів потоку, що включає в себе синтез кола заміщення імпульсної температурної релаксації та спосіб формування ВАХ перетворювачів в режимі їх самонагріву струмом живлення. З точки зору практичного використання транзисторів у схемах вимірювальних перетворювачів термодатчиків необхідно забезпечити не тільки достатній нагрів структури транзистора, але й достатню електричну термостійкість його функціонування. Для цього необхідно використовувати, зокрема, емітуючі стабілізуючі резистори або диференціальне з'єднання пари транзисторів з джерелом струму.

Ключові слова: вимірювальні перетворювачі, електротеплове моделювання, самонагрів перетворювачів, біомедичні прилади та системи.

Abstract. Considered problems of instability of iterative processes in the analysis of I/V measuring converters with negative differential resistance caused by self-heating of these converters. An express method of determining the limits in which correct electrothermal DC analysis is provided has been developed. According to the problems considered the method of the synthesis of the electrothermal model of the transistor structures of thermal flow sensors. Analyzing the model of the bipolar transistor from the point of view of the impact of self-heating temperature on VAC, it is necessary to consider, at least, three mechanisms of temperature impact. It should be noted that, as in the models presented before, we speak not only of the impact of the ambient temperature on the parameters of the transistor, but on its self-heating, i.e., direct impact of power released in the transistor structure on its electric physical parameters. A method of synthesis of electrothermal models of thermoresistive, diode and transistor structures of primary converters of thermal flow sensors is proposed. In contrast to well-known circuit modeling packages (PSpice or MicroCAP), the proposed method allows you to obtain I-V characteristics in one cycle of DC analysis, taking into account the self-heating of the above-mentioned converters. A complex method of electro-thermal modeling of measuring transducers of thermal flow sensors has been developed, which includes the synthesis of a pulse temperature relaxation substitution circuit and a method of forming I-V converters in the mode of their self-heating by the supply current. It is obvious, that from the point of view of practical usage of the transistors in the circuits of measuring converters of thermal flow sensors it is necessary to provide not only the sufficient heating of the transistor structure but also the sufficient electric thermal stability of its operation. For this purpose it is necessary to use, in particular, emitting stabilizing resistors or differential connection of the pair of the transistors with current supply.

Keywords: measuring transducers, electrothermal modeling, biomedical devices and systems.

DOI: <https://doi.org/10.31649/1999-9941-2024-59-1-62-68>.

Introduction

In the given section complex technique of the electric thermal modeling of the measuring converters of thermal flow sensors, is presented; it contains the synthesis of the equivalent circuit of the pulse temperature relaxation and the method of formation of converters VAC in the self heating mode by the supply current. Problems of the iteration process instability in the process of VAC analysis of the measuring converters with negative differential resistance, caused by self-heating, are considered [1,2,3].

Method of the synthesis of electric thermal models of thermoresistive, diode and transistor structures of the primary thermal flow sensors converters was suggested. Unlike the known packages of circuit modeling this method enables one to obtain VAC during one cycle of DC analysis, taking into account the self-heating of the above-mentioned converters [4,5,6,].

Method

Primary converters of thermal flow sensors can serve not only thermoresistive or diode structures but transistors, mainly bipolar n-p-n structures. Their advantage is a wide range of the supply (heating) modes and temperature measurement modes selection. Basic heating in the bipolar structures is realized by the heat release on the reverse-biased p-n junction. As it will be shown in Section 4, unlike thermoresistive converters the usage of the transistor structure enables it to form the current output that provides higher values of transducing steepness [7,8,9].

From the point of view of primary converters of thermal flow sensors, the advantage of the transistor structures as compared with the diode structures is more efficient usage of the supply circuit energy - voltage drop on diode structures, as a rule, does not exceed 0.8 V (for silicon structures), it means, in particular, that at 5 V supply source practically the whole voltage ($5 - 0.8 = 4.2$ V) drops on current forcing circuit. It is obvious that not more than 20 % of supply circuit energy will be spent on heating the diode structure. Instead, the voltage drop on the transistor structure (on reverse-biased collector p-n junction) can be randomly regulated by the resistive divider of basic circuit voltage, that provides maximum energy profit [10,11,12].

According to the problems, put forward in this section, we will consider the method of the synthesis of the electrothermal model of the transistor structures of thermal flow sensors. Analyzing the model of the bipolar transistor from the point of view of the impact of self-heating temperature on VAC, it is necessary to consider, at least, three mechanisms of temperature impact. It should be noted, that, as in the models presented before, we speak not only of the impact of the ambient temperature on the parameters of the transistor, but on its self-heating, i.e., direct impact of power released in the transistor structure on its electric physical parameters. It is obvious that model studies of self-heating must be conducted in a single cycle, when the temperature is not an independent value but is determined by the power of the transistor [13,14,15].

The first mechanism of the temperature impact is analogous to the above-mentioned diode structures - increase of temperature stipulates the decrease of voltage drop on p-n junction $V_{pn} = f_1(T)$ of the transistor structure. In case of direct connection of the transistor the temperature drift of voltage on emitter - base junction is important, and in case of inverse connection - on collector-base junction. The second mechanism is connected with the sharp increase of the reverse currents of p-n junction $I_S = f_2(T)$ in the process of their heating - mainly, reverse-biased collector-base junction. The third mechanism of the impact - it is the temperature drift of the current increase coefficient of the transistor structure $B_F = f_3(T)$. These three mechanisms were taken into consideration in the process of model development (equivalent circuit) of the electric thermal analysis of the bipolar transistor VAC (Fig. 1).

Thermal modeling of the resistive and diode structures

The given equivalent circuit is based on Ebers-Moll model (if necessary it may be based on the still more complex Poon-Gummel charging model) as well as on the principles of electric thermal modeling of the resistive and diode structures, considered in the previous sections [16,17,18].

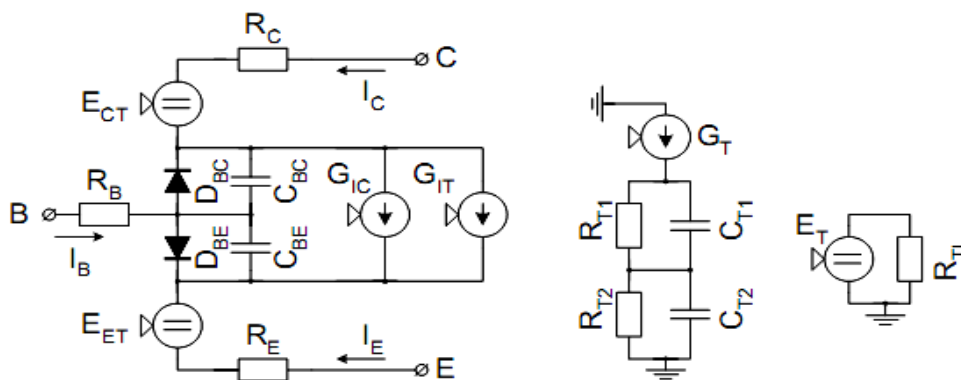

Figure 1 –Model of electric thermal analysis of the bipolar transistor VAC

Conventional for Ebers-Moll model [1, 2] is emitter and collector p-n junction D_{BE} , D_{BC} , stray barrier capacitance of which is presented by the capacitors C_{BE} , C_{BC} . Resistive components of the transistor structure are presented by the resistances of base, emitter and collector sections R_B , R_E , R_C . Current transmission coefficient of the structure is described by the controlled current source G_{IC} . Mathematical presentation of such a traditional transistor model is described in detail in the monographs and instruction manuals, using PSpice or MicroCAP packages [2, 3], that is why, its further consideration is not performed [19,20,21].

The characteristic feature of the suggested model is the presence of two controlled voltage sources E_{CT} , E_{ET} and controlled current source G_{IT} . Besides, the electric thermal model contains the above-considered circuits of pulse thermal relaxation G_T , R_{T1} , C_{T1} , R_{T2} , C_{T2} and thermal resistance E_T , R_{TL} . Principles of voltage sources specification E_{CT} , E_{ET} , which form temperature-dependent component of the voltage drop on the forward-biased p-n junction $\Delta V_{pn} = f_1(T)$, have already been considered in the process of the electric thermal study of the diode structures [22].

The impact of the temperature on the current of the reverse-biased p-n junction $I_S = f_2(T)$ similarly Ebers-Moll model can be represented in the form:

$$I_S T = I_{S0} \exp\left(\left(\frac{T}{T_0} - 1\right) \frac{E_G(T)}{\phi_T}\right) \left(\frac{T}{T_0}\right)^{X_{T1}}$$

where X_{T1} – is the exponent of the temperature dependence of the reverse current I_{S0} .

The reverse currents (typically not greater than several microamperes) as compared with the heating current (hundreds of milliamperes) can be neglected. However, the participation of the reverse-biased collector p-n junction current in the total basic current, amplified several hundreds of times, cannot be neglected. That is why, it is expedient to combine it with the third mechanism - temperature drift of current amplification factor of the transistor structure $B_F = f_3(T)$:

$$B_F(T) = B_F \left(\frac{T}{T_0}\right)^{X_{TB}}$$

where X_{TB} – is the exponent of the temperature dependence of the current amplification factor B_F . This combined mechanism is presented by the controlled source G_{IT} .

Demonstration of the efficiency of the developed electric thermal model

For the demonstration of the efficiency of the developed electric thermal model of the transistor self heating we will consider two typical results of its output VAC modeling (Fig. 2-5).

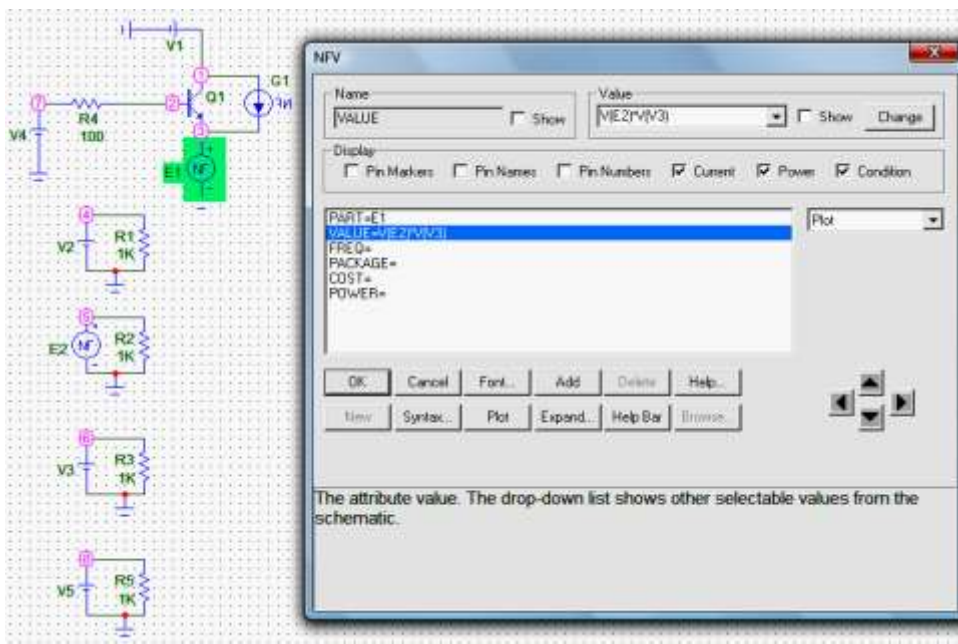

Figure 2 – Specification of the controlled voltage source of the electric thermal model of the bipolar transistor

To simplify the results, given below, not a separate components of the transistor equivalent circuit are used but the conventional Ebers-Moll model (n-p-n transistor Q1) is used, the given model, for carrying out the electric thermal modeling is supplemented with the corresponding controlled sources: source E1 describes functional dependence $\Delta V_{pn} = f_1(T)$, source G1 - functional dependencies $I_S = f_2(T)$ and $B_F = f_3(T)$, source V2 - thermal resistance of the transistor structure, source E2 - overheating temperature of the structure, relatively the ambient temperature, source V3 – TKV_{pn} coefficient, and source V5 – coefficients X_{T1} and X_{TB} . The supply voltage of the collector circuit is supplied from the source V1, and base circuit - from the source V4 and resistor R4.

Experimental results

The first result of modeling (Fig. 3) is obtained only with the account of the temperature dependence of the voltage drop on the emitter p-n junction. It can be seen that if the transistor current increases (signal 1), its heating occurs and (signal 2) voltage drop decrease on the emitter p-n junction (signal 3) takes place. These effects increase if the thermal resistance (graphs a, b, c) of the transistor structure increases.

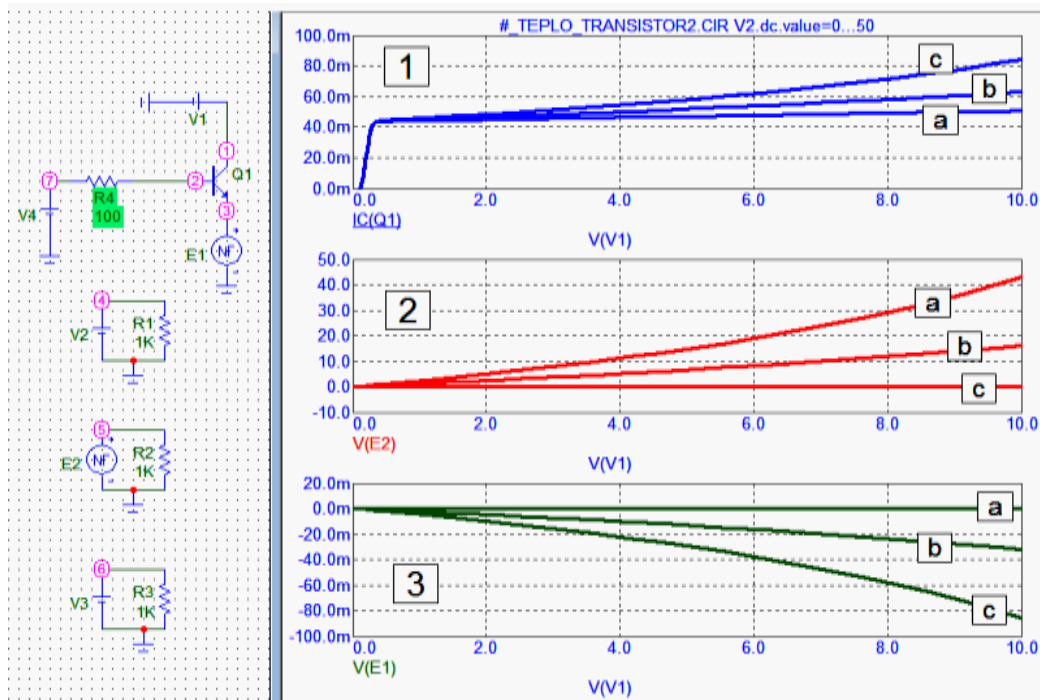

Figure 3 – Result of DC analysis of the bipolar transistor output VAC with the account of $V_{pn} = f_1(T)$ mechanism at several values of the thermal resistance Z_Q

The second result of modeling (Fig 4) takes into account all the above-considered mechanisms of the temperature impact. As it is seen, the modulation of the transistor VAC in the process of its self heating is greater, it is stipulated not only by the temperature drift of the voltage on the emitter p-n junction but also by the increase of the current amplification coefficient of the transistor in the process of its self-heating.

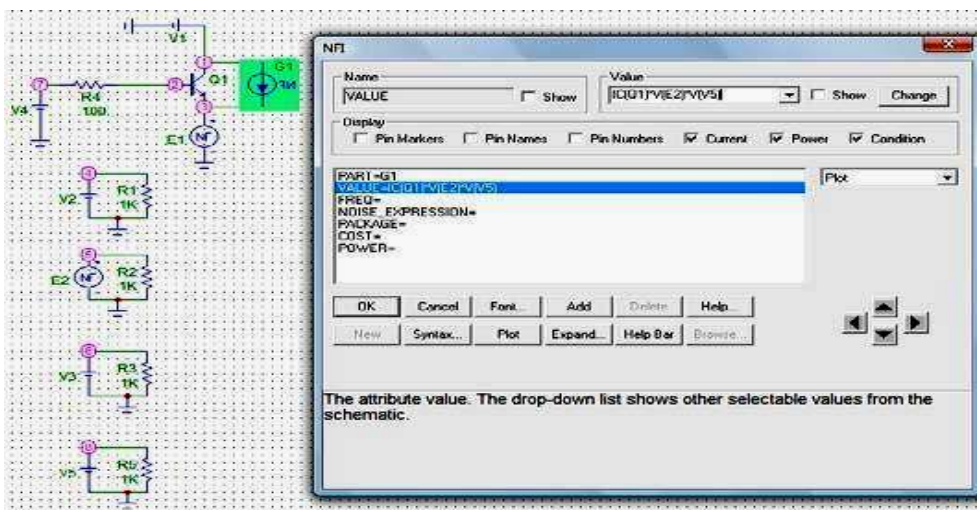

Figure 4 – Specification of the controlled current source of the bipolar transistor electric thermal model

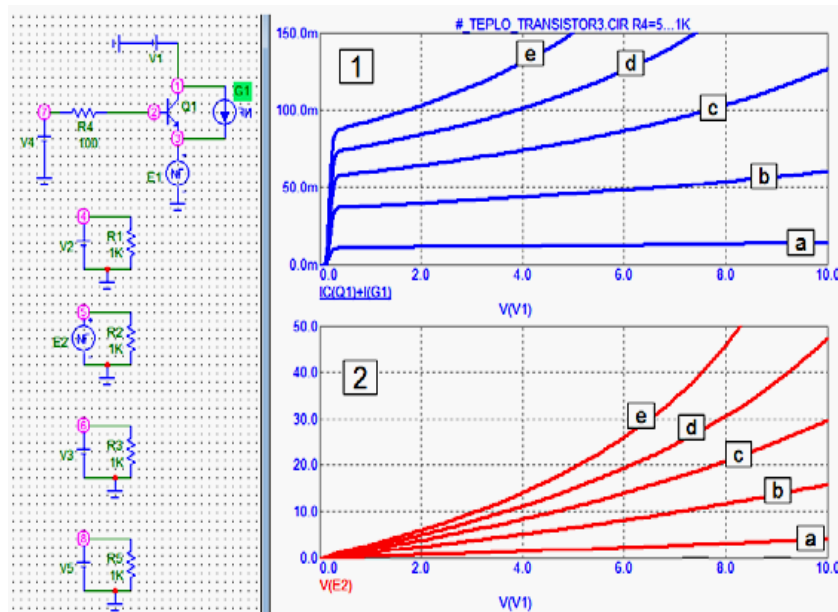

Figure 5 – Result of DC analysis of bipolar transistor VAC with the account of the mechanisms $V_{pn} = f_1(T)$, $I_S = f_2(T)$, $B_F = f_3(T)$ at several values of thermal resistance Z_Q

Conclusions

1. It is obvious, that from the point of view of practical usage of the transistors in the circuits of measuring converters of thermal flow sensors it is necessary to provide not only the sufficient heating of the transistor structure but also the sufficient electric thermal stability of its operation. For this purpose it is necessary to use, in particular, emitting stabilizing resistors or differential connection of the pair of the transistors with current supply.
2. A method of synthesis of electrothermal models of thermoresistive, diode and transistor structures of primary converters of thermal flow sensors is proposed. In contrast to well-known circuit modeling packages (PSpice or MicroCAP), the proposed method allows you to obtain I-V characteristics in one cycle of DC analysis, taking into account the self-heating of the above-mentioned converters.
3. A complex method of electro-thermal modeling of measuring transducers of thermal flow sensors has been developed, which includes the synthesis of a pulse temperature relaxation substitution circuit and a method of forming I-V converters in the mode of their self-heating by the supply current.

References

- [1] Y. Fang and W. W. Liou. Computations of the Flow and Heat Transfer in Microdevices Using DSMC With Implicit Boundary Conditions // J. Heat Transfer. – 2002. – Vol. 124. – P. 338–345.
- [2] W.W. Liou and Y. Fang. Implicit Boundary Conditions for Direct Simulation Monte Carlo Method in MEMS Flow Predictions // CMES. – 2000. – Vol. 1, No. 4, – P. 119–128.
- [3] Y. Weiping, L. Chong, L. Jianhua, M. Lingzhi and N. Defang. Thermal distribution microfluidic sensor based on silicon // Sensors and Actuators B. – 2005. – Vol. 108. – P. 943–946.
- [4] B.W. van Oudheusden. Silicon thermal flow sensors // Sensors and Actuators A: Phys. – 1992. № 30. – PP. 5–26.
- [5] M. Ashauer, H. Glosch, F. Hedrich, N. Hey, H. Sandmaier, W. Lang. Thermal flow sensor for liquids and gases based on combinations of two principles // Sensors and Actuators A. – 1999. Vol. 73. – PP. 7–13.
- [6] F. Jiang, Y.-C. Tai, C.-M. Ho, R. Karan, M. Garstenauer. Theoretical and experimental studies of micromachined hot-wire anemometers // International Electron Devices Meeting (IEDM), San Francisco, December 11–14. – 1994. PP. 139-142.
- [7] J.J. van Baar, R.W. Wiegerink, T.S.J. Lammerink, G.J.M. Krijnen, M. Elwenspoek. Micromachined structures for the thermal measurements of fluid and flow parameters // J. Micromech. Microeng. – 2001. – № 11. – PP. 311–318.

- [8] T. S. T. Lammerink, N. R. Tas, M. Elwenspoek, J. H. J. Fluitman. Micro-liquid flow sensor // *Sensors and Actuators A*. – 1993. – PP. 45-50.
- [9] P.M. Handford, P. Bradshaw. The pulsed-wire anemometer // *Exp. Fluids* 7. – 1989. – PP. 125–132.
- [10] Ellis Menga, Po-Ying Li, Yu-Chong Tai. A biocompatible Parylene thermal flow sensing array // *Sensors and Actuators A*. – 2008. № 144. –PP. 18–28.
- [11] A. Margelov. Honeywell gas flow sensors [Electronic resource] / A. Margelov // *Chip News*. — 2005. — № 9 (102). — С.56—58.
- [12] Z.Yu. Gotra, R.L. Holyaka, S.V. Pavlov, S.S. Kulenko, O.V. Manus Differential thermometer with high resolution // *Technology and construction in electronic equipment*. - 2009. - No. 6 (84). - P. 19 - 23.3.Ю.
- [13] Pavlov S. V. *Information Technology in Medical Diagnostics* //Waldemar Wójcik, Andrzej Smolarz, July 11, 2017 by CRC Press - 210 Pages.
- [14] Wójcik W., Pavlov S., Kalimoldayev M. *Information Technology in Medical Diagnostics II*. London: (2019). Taylor & Francis Group, CRC Press, Balkema book. – 336 Pages.
- [15] *Highly linear Microelectronic Sensors Signal Converters Based on Push-Pull Amplifier Circuits* / edited by Waldemar Wojcik and Sergii Pavlov, Monograph, (2022) NR 181, Lublin, Comitet Inzynierii Srodowiska PAN, 283 Pages. ISBN 978-83-63714-80-2.
- [16] Pavlov Sergii, Avrunin Oleg, Hrushko Oleksandr, and etc. System of three-dimensional human face images formation for plastic and reconstructive medicine // *Teaching and subjects on bio-medical engineering Approaches and experiences from the BIOART-project Peter Arras and David Luengo (Eds.)*, 2021, Corresponding authors, Peter Arras and David Luengo. Printed by Acco cv, Leuven (Belgium). - 22 P. ISBN: 978-94-641-4245-7.
- [17] Kukharchuk, Vasyl V., Sergii V. Pavlov, Volodymyr S. Holodiuk, Valery E. Kryvonosov, Krzysztof Skorupski, Assel Mussabekova, and Gaini Karnakova. 2022. "Information Conversion in Measuring Channels with Optoelectronic Sensors" *Sensors* 22, no. 1: 271. <https://doi.org/10.3390/s22010271>
- [18] Avrunin, O.G.; Nosova, Y.V.; Pavlov, S.V.; Shushliapina, N.O.; and etc. Research Active Posterior Rhinomanometry Tomography Method for Nasal Breathing Determining Violations. *Sensors* **2021**, *21*, 8508. doi: 10.3390/s21248508, <https://www.mdpi.com/1424-8220/21/24/8508>.
- [19] Avrunin, O.G.; Nosova, Y.V.; Pavlov, S.V.; and etc. Possibilities of Automated Diagnostics of Odontogenic Sinusitis According to the Computer Tomography Data. *Sensors* 2021, 21, 1198. <https://doi.org/10.3390/s21041198>.
- [20] Vasyl V. Kukharchuk, Sergii V. Pavlov, Samoil Sh. Katsyv, and etc. "Transient analysis in 1st order electrical circuits in violation of commutation laws", *PRZEGLĄD ELEKTROTECHNICZNY*, ISSN 0033-2097, R. 97 NR 9/2021, p. 26-29, doi:10.15199/48.2021.09.05.
- [21] *Sensors of electric magnetic radiation for bioengineering research* / G. S. Tymchyk; V. I. Skytsiuk, M. A. Waintraub, T. R. Klochko. – K. : S.E. Lesia, 2004. – 64 p.
- [22] Osadchuk O. V Microelectronic frequency converters on the base of the transistor structures with negative resistance / O. V. Osadchuk. – Vinnytsia: UNIVERSUM- Vinnytsia, 2000. – 303 p.

Надійшла до редакції 20.03.2024

Видано за грантової підтримки Національного фонду досліджень України в рамках проекту 2022.01/0135 "Розробка лазерно-фотонного лікувально-діагностичного комплексу медичної реабілітації пацієнтів з політравмами різного ступеня важкості"

Information about authors

Pavlov Sergii – D.Sc., Professor of Biomedical Engineering and Optic-Electronic Systems Department, Vinnytsia National Technical University

Wójcik Waldemar – D.Sc., Professor, director of the Institute of Electronics and Information Technology at Lublin University of Technology. Doctor Honoris Causa of five Universities in Ukraine and Kazakhstan

Holyaka Roman – D.Sc., Professor of Electronic Device of Information-Computer Technologies Department, Lviv Polytechnic National University

Azarov Olexiy – D.Sc. Professor, head of Computer Technology Department, Vinnytsia National Technical University

Nykyforova Larysa - Doctor of Technical Sciences, Professor of the Department of Automation and Robotic Systems named after Academician I.I. Martynenko, *National University of Life and Environmental Sciences of Ukraine*

Kaduk Oleksandr - Ph.D., associate professor associate professor of Computer Engineering Department, Vinnytsia National Technical University

С.В.Павлов¹, Вальдемар Вуйцік², Р.Л. Голяка³, О.Д. Азаров¹,
Л.Є. Никифорова⁴, О.В. Кадук¹

ЕЛЕКТРОТЕРМІЧНЕ МОДЕЛЮВАННЯ ТЕМПЕРАТУРНО-ЗАЛЕЖНИХ ВАХ ПЕРЕТВОРЮВАЧІВ ТРАНЗИСТОРНОГО ТИПУ В БІОМЕДИЧНІЙ ІНЖЕНЕРІЇ

¹Вінницький національний технічний університет

²Люблінський університет технологій, Польща

³Національний університет «Львівська Політехніка»

⁴Національний університет біоресурсів та природокористування України